

HOLLY

floor lamp

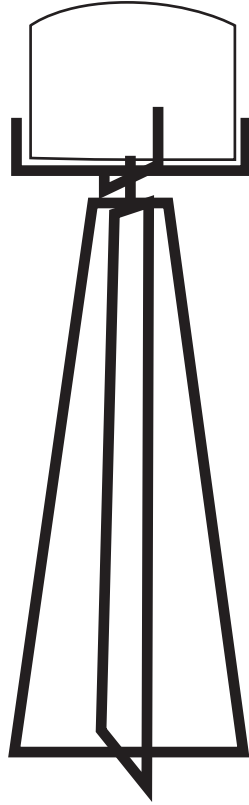

ATTENTION: READ THE MANUAL CAREFULLY BEFORE INSTALLING THE LAMP

Rated power E 27, Max. 40W

WARNING

1. Ensure the lamp is disconnected from mains power before installation.
2. Make sure the lamp is securely supported.
3. Just for indoor use.

IMPORTANT:

1. Wear gloves during installation. Avoid scratching the lamp surface
2. Ensure that the electrical supply complies with the type stated on rating label.
3. Used lighting source shall be of suitable model and wattage
4. Avoid touching the shade and bulb when the lamp is working
5. Please cut off power and let the bulb and shade cool down before replacing the bulb.
6. Please use dry cloth to clean the lamp.
7. If the external flexible cable or cord of this luminaire is damaged, it shall be exclusively replaced by the manufacturer or his service agent or a similar qualified person in order to avoid a hazard.

HOLLY

floor lamp

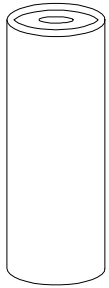

A - 1 PCS



B - 2 PCS

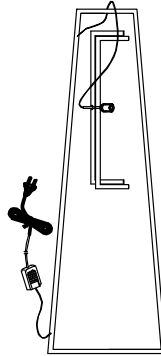

C - 1 PCS



D - 1 PCS
4X12MM

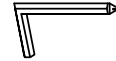

E - 1 PCS

1

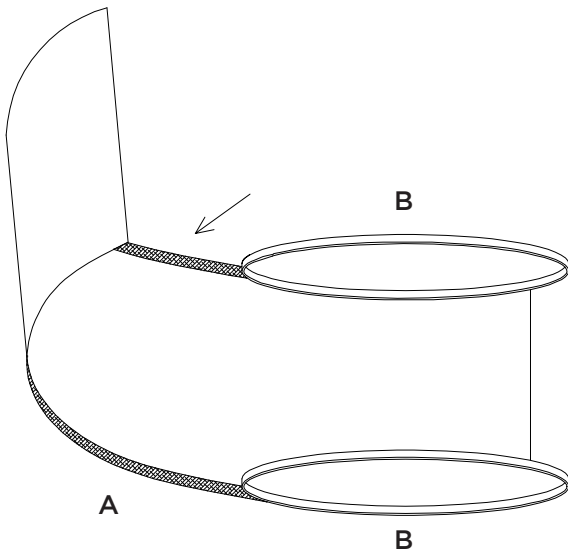

2

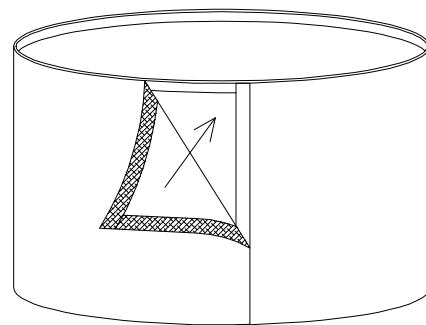

HOLLY

floor lamp

3

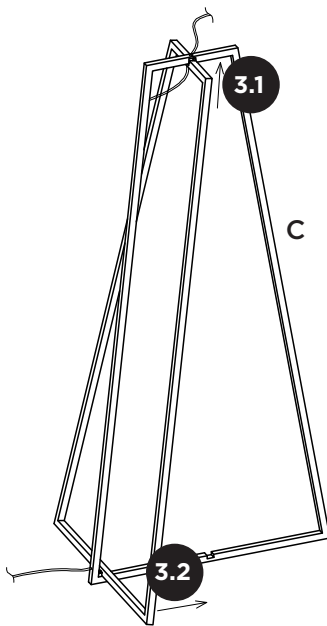

4

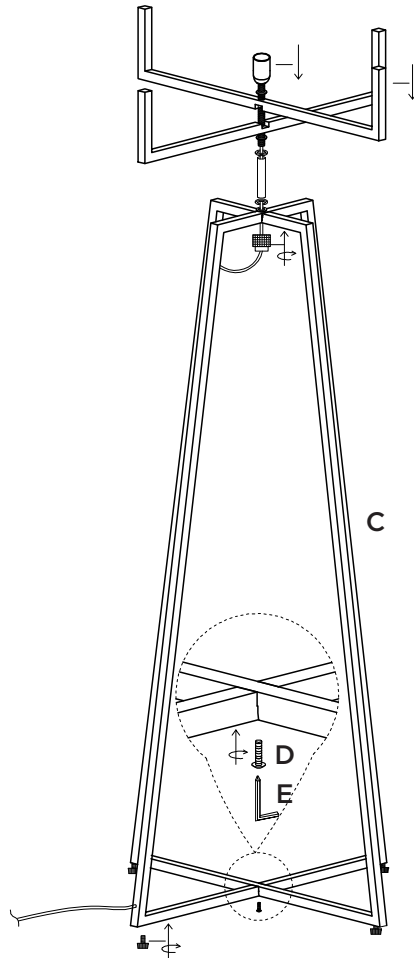

5

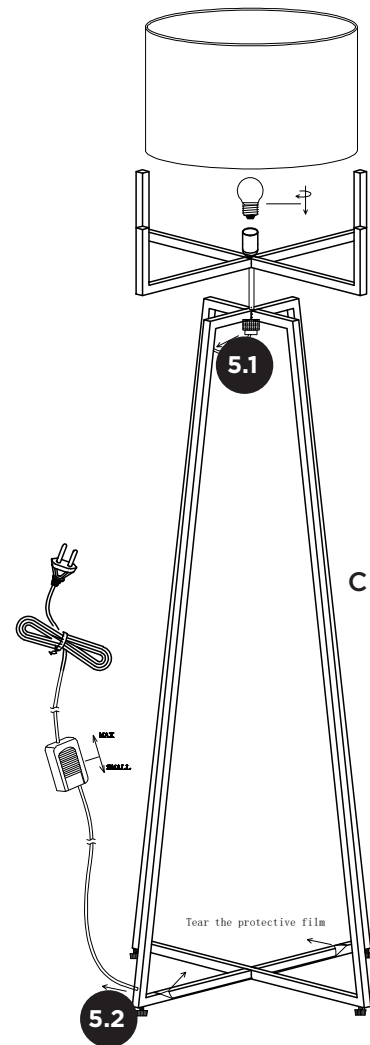

- MOUNTING INSTRUCTIONS -

NL: Tip bij harde vloeren: Plaats viltglijders onder de poten. Dit voorkomt beschadiging aan harde vloeren.

UK: Tip for hard floors: Place felt glides under the legs. This prevents damage to hard floors.

DE: Tipp für harte Böden: Ort Filzgleiter unter den Beinen. Dies verhindert Schäden an harten Böden.

FR: Conseil pour les sols durs : Placez des patins en feutre sous les jambes. Cela évite d'endommager les sols durs.